

# EVOC

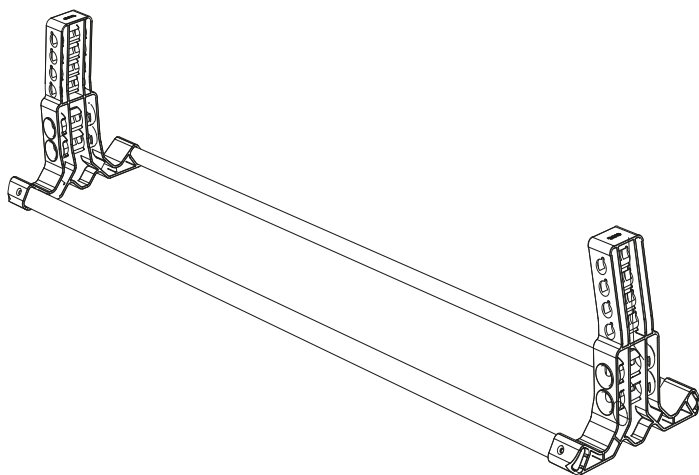

INSTRUCTION MANUAL  
FOR MOUNTING A BIKE ON YOUR  
BIKE STAND PRO

ENCLOSED



4x ALUMINIUM RAILS

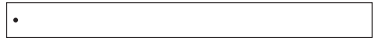

2x HUBS

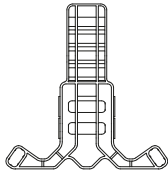

**4x FRONT AXLE ADAPTERS:**

2 x QR 5 mm



2 x Thru axle 12 mm



2 x Thru axle 15 mm



2 x Thru axle 20 mm



BOOST RING



**6x REAR AXLE ADAPTERS:**

5 x 130mm

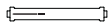

12 x 135 mm



5 x 142mm

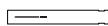

12 x 148 mm



5 x 150mm



12 x 157mm

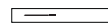

5 x 100mm

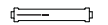

12 x 100mm

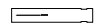

FITS MOST MTB, DH-, ROAD-, GRAVEL- AND TRIATHLON BIKEST

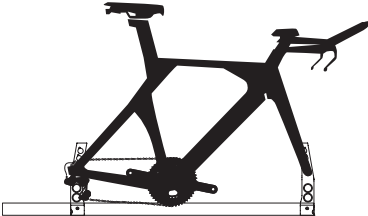
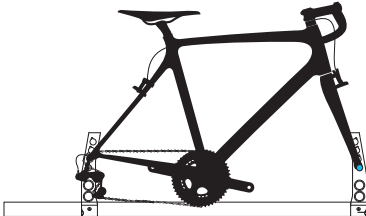
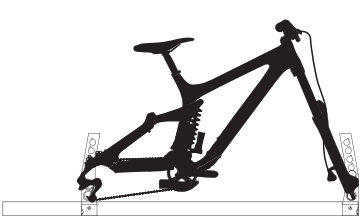

---

HOW TO ASSEMBLE YOUR BIKE STAND PRO

// 01

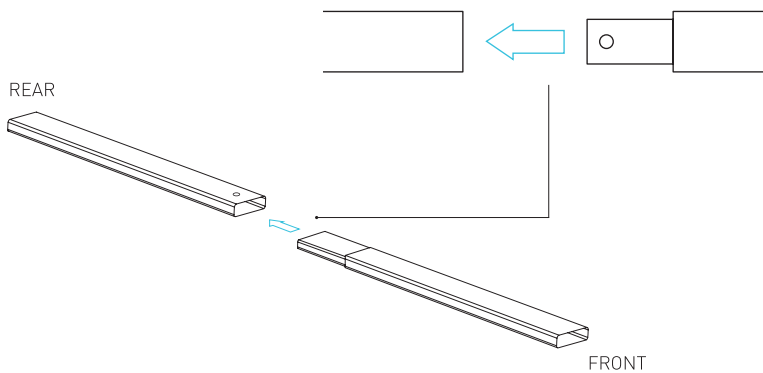

// 02

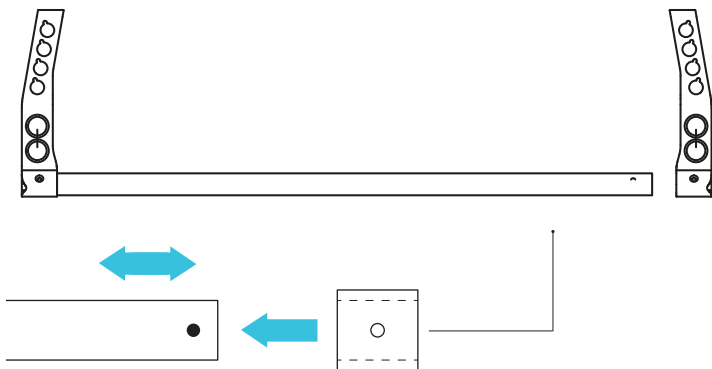

## BIKE PREPARATION

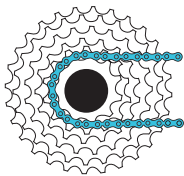

Chain on smallest sprocket

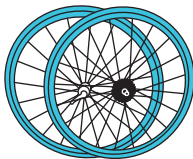

Remove wheels  
and axles/skewers

## MOUNTING YOUR BIKE ON ROAD BIKE STAND

// 01

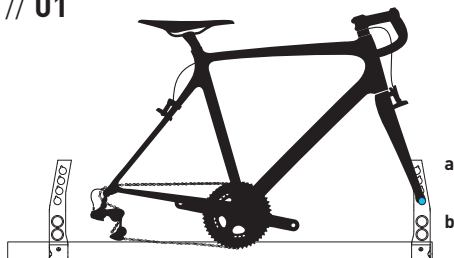

Place fork on front hub with correct front axle adapters. Tighten your front axle.

// 02

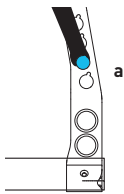

a) Top level

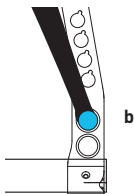

b) Low level

// 03

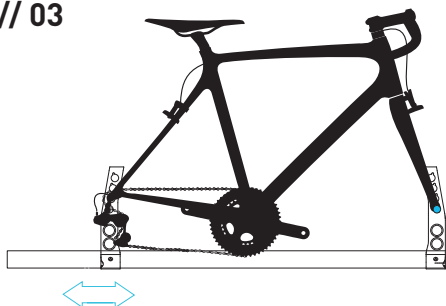

Adjust position of rear hub according to your wheel base.

Place rear drop-outs on rear hub with correct rear axle adapter. Tighten your rear axle.

// 04

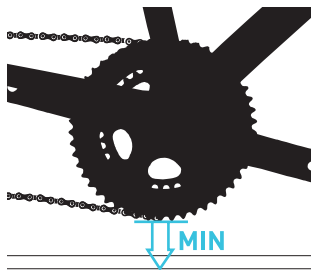

Always choose lowest possible level at rear hub according to chain wheel size.

---

ADDITIONAL BIKE PREPARATION FOR USE IN EVOC BIKE TRAVEL BAGS

// 01

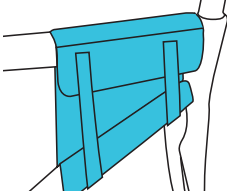

Add FRAME PAD

// 02

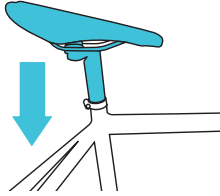

Lower your bicycle saddle

// 03

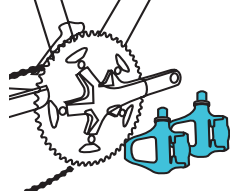

Remove both pedals

// 04

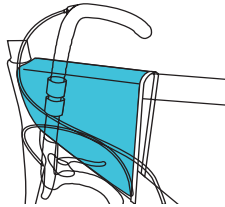
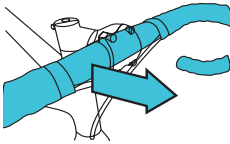

If necessary remove handle bar and fix it on FRAME PAD

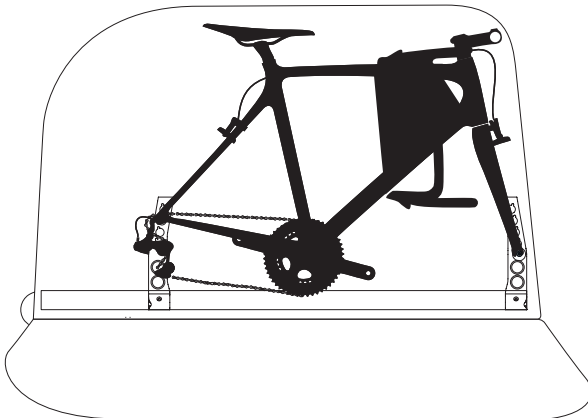

---

WARRANTY AND AFTER SALES SERVICE



WARRANTY

<https://www.evocsports.com/service/warranty>